



Aplicaciones

Se utilizan los guardacabos para proteger cables, estachas o cabos sintéticos. Disponibles en varios modelos y tamaños. Todos los guardacabos indicados pueden ser utilizados en combinación con los elementos arriba mencionados.

Gama

Van Beest ofrece una gama amplia de guardacabos, desde modelos nacionales hasta todo tipo de modelo disponible en el mercado.

Diseño

Los guardacabos pueden ser fabricados con diferentes tipos de acero, en frío, en caliente o fundido, dependiendo de su uso específico.

Acabado

El acabado suele ser pintado, electro galvanizado o galvanizado en caliente.

Certificación

Bajo petición, todos los guardacabos pueden ser suministrados con certificado de fábrica.

Instrucciones de uso

Los guardacabos deben ser inspeccionados regularmente según las normas de cada país. Esto es necesario porque los productos pueden estar afectados por desgaste, mal uso, o sobrecargas produciendo deformaciones o alteraciones de la estructura del acero.

Las dimensiones de los guardacabos tienen que adaptarse perfectamente al cable. El tamaño nominal del guardacabo es el diámetro del cable utilizado. Para cable de tamaños intermedios, hay que usar un guardacabo de un tamaño superior.

Antes de usarlo, compruebe que el guardacabo no tiene desperfectos, cantos vivos, fisuras u otras irregularidades que podrían dañar el cable y afectar su resistencia o función.

Guardacabos

Comercial Standard

- **Material** : acero dulce
- **Acabado** : electro galvanizado
- **Certificación** : bajo petición, certificado de fábrica

| diámetro cable | ancho ranura | longitud | ancho | longitud interior | ancho interior | peso cada 100 pcs |
|----------------|--------------|----------|-------|-------------------|----------------|-------------------|
| mm | a mm | b mm | c mm | d mm | e mm | kg |
| 4 | 4 | 25 | 19 | 16 | 11 | 0.4 |
| 5 | 5 | 31 | 22 | 22 | 16 | 0.8 |
| 6 | 6 | 37 | 29 | 26 | 19 | 1.4 |
| 7 | 7 | 44 | 32 | 32 | 22 | 2 |
| 8 | 8 | 51 | 38 | 34 | 24 | 2.8 |
| 9 | 9 | 57 | 42 | 38 | 29 | 3 |
| 10 | 10 | 64 | 44 | 42 | 32 | 4.8 |
| 11 | 11 | 70 | 51 | 48 | 35 | 7.5 |
| 12 | 12 | 76 | 57 | 51 | 38 | 8 |
| 14 | 14 | 82 | 60 | 57 | 40 | 10 |
| 16 | 16 | 89 | 64 | 60 | 42 | 15 |
| 18 | 18 | 102 | 69 | 67 | 45 | 22 |
| 20 | 20 | 115 | 79 | 76 | 51 | 25 |
| 22 | 22 | 127 | 89 | 83 | 54 | 32 |
| 24 | 24 | 140 | 102 | 88 | 64 | 46 |
| 26 | 26 | 152 | 105 | 102 | 68 | 66 |
| 28 | 28 | 165 | 115 | 110 | 73 | 77 |
| 30 | 30 | 178 | 121 | 115 | 79 | 80 |
| 32 | 32 | 203 | 133 | 140 | 93 | 130 |

E-6110

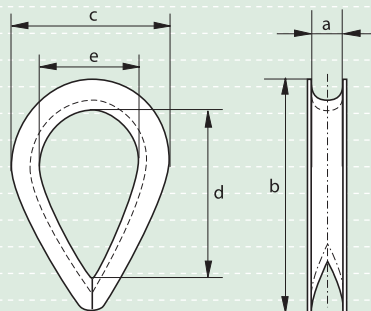

Guardacabos

De trabajos pesados

- **Material** : acero dulce
- **Acabado** : electro galvanizado
- **Certificación** : bajo petición, certificado de fábrica

| diámetro cable | ancho ranura | longitud | longitud interior | ancho interior | espesor chapa | peso cada 100 pcs |
|----------------|--------------|----------|-------------------|----------------|---------------|-------------------|
| mm | a mm | b mm | c mm | d mm | e mm | kg |
| 8 | 8 | 51 | 35 | 22 | 4 | 6 |
| 10 | 10 | 64 | 47 | 30 | 4 | 7 |
| 12 | 12 | 76 | 57 | 35 | 5 | 14 |
| 14 | 14 | 89 | 65 | 45 | 6 | 22 |
| 16 | 16 | 102 | 76 | 50 | 6 | 24 |
| 18 | 18 | 114 | 86 | 53 | 8 | 43 |
| 20 | 20 | 127 | 94 | 60 | 9 | 65 |
| 22 | 22 | 140 | 107 | 65 | 10 | 93 |
| 24 | 24 | 152 | 114 | 70 | 10 | 102 |
| 28 | 28 | 178 | 130 | 80 | 10.5 | 135 |
| 32 | 32 | 203 | 157 | 100 | 10.5 | 162 |
| 36 | 36 | 229 | 177 | 115 | 12 | 363 |
| 40 | 40 | 254 | 198 | 120 | 12 | 376 |
| 44 | 44 | 279 | 214 | 130 | 15 | 608 |
| 50 | 50 | 305 | 215 | 140 | 20 | 960 |
| 56 | 56 | 356 | 245 | 160 | 20 | 1400 |
| 64 | 64 | 407 | 275 | 180 | 20 | 1700 |

E-6120

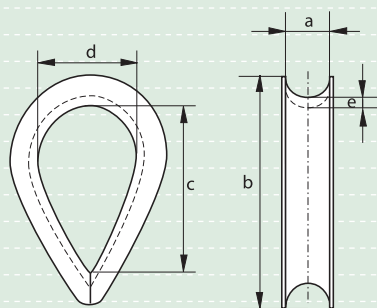



E-6131

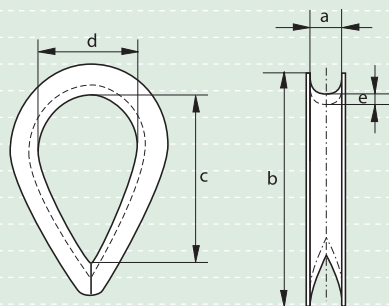

Guardacabos

Generalmente según DIN 6899 (B)

- **Material** : acero dulce
- **Norma** : generalmente según DIN 6899 (B)
- **Acabado** : electro galvanizado
- **Certificación** : bajo petición, certificado de fábrica

| diámetro cable | ancho ranura | longitud | longitud interior | ancho interior | espesor chapa | peso cada 100 pcs |
|----------------|--------------|----------|-------------------|----------------|---------------|-------------------|
| mm | a mm | b mm | c mm | d mm | e mm | kg |
| 2.5 | 3 | 22 | 19 | 12 | 1.6 | 0.5 |
| 3.5 | 4 | 26 | 21 | 13 | 1.6 | 0.8 |
| 4 | 5 | 32 | 23 | 14 | 1.9 | 1 |
| 5 | 6 | 38 | 25 | 16 | 2.4 | 1.6 |
| 6 | 7 | 44 | 28 | 18 | 2.4 | 1.9 |
| 7 | 8 | 51 | 32 | 20 | 2.8 | 3 |
| 9 | 10 | 57 | 38 | 24 | 3.1 | 4.7 |
| 11 | 12 | 64 | 45 | 28 | 3.3 | 6.8 |
| 13 | 13 | 70 | 48 | 30 | 3.3 | 8 |
| 13 | 14 | 76 | 51 | 32 | 3.7 | 10 |
| 15 | 16 | 83 | 58 | 36 | 3.8 | 14.5 |
| 16 | 17 | 89 | 61 | 38 | 4.7 | 18 |
| 17 | 18 | 95 | 64 | 40 | 4.7 | 20 |
| 18 | 20 | 102 | 72 | 45 | 5.7 | 29 |
| 20 | 22 | 114 | 80 | 50 | 5.7 | 32 |
| 22 | 24 | 127 | 90 | 56 | 6.5 | 47 |
| 24 | 26 | 140 | 99 | 62 | 6.8 | 59 |
| 26 | 28 | 152 | 112 | 70 | 8 | 80 |
| 28 | 30 | 165 | 120 | 75 | 8 | 110 |
| 30 | 32 | 178 | 128 | 80 | 8 | 123 |
| 32 | 34 | 203 | 152 | 95 | 8.5 | 156 |
| 34 | 36 | 216 | 160 | 100 | 8.5 | 176 |
| 36 | 38 | 229 | 176 | 110 | 8.5 | 192 |
| 38 | 40 | 241 | 184 | 115 | 10.5 | 292 |
| 40 | 42 | 254 | 192 | 120 | 10.5 | 320 |
| 42 | 45 | 305 | 240 | 150 | 10.5 | 364 |



G-6132

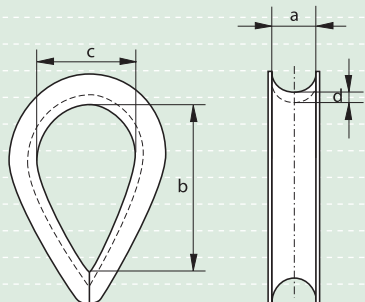

Guardacabos

Generalmente según DIN 6899 (C)

- **Material** : acero dulce
- **Norma** : generalmente según DIN 6899 (C)
- **Acabado** : galvanizado en caliente
- **Certificación** : bajo petición, certificado de fábrica

| diámetro cable | ancho ranura | longitud interior | ancho interior | espesor chapa | peso cada 100 pcs |
|----------------|--------------|-------------------|----------------|---------------|-------------------|
| mm | a mm | b mm | c mm | d mm | kg |
| 11 | 12 | 59 | 27.5 | 6.5 | 24 |
| 12 | 13 | 64 | 30 | 7 | 25 |
| 14 | 15 | 75 | 35 | 8 | 35 |
| 16 | 18 | 86 | 40 | 9.5 | 65 |
| 18 | 20 | 96 | 45 | 11 | 102 |
| 20 | 22 | 107 | 50 | 12 | 135 |
| 22 | 24 | 118 | 55 | 13 | 179 |
| 24 | 26 | 128 | 60 | 14.5 | 227 |
| 26 | 28 | 139 | 65 | 15.5 | 264 |
| 28 | 31 | 150 | 70 | 17 | 400 |
| 32 | 35 | 171 | 80 | 19 | 520 |
| 36 | 40 | 192 | 90 | 21.5 | 575 |
| 40 | 44 | 215 | 100 | 24 | 1010 |
| 44 | 48 | 235 | 110 | 26.5 | 1180 |
| 48 | 53 | 257 | 120 | 29 | 1940 |



G-6133

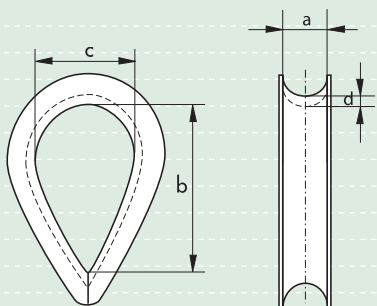

Guardacabos

Generalmente según DIN 83311

- **Material** : acero dulce
- **Norma** : generalmente según DIN 83311
- **Acabado** : galvanizado en caliente
- **Certificación** : bajo petición, certificado de fábrica

| tamaño nominal | ancho ranura | longitud interior | ancho interior | espesor chapa | peso cada 100 pcs |
|----------------|--------------|-------------------|----------------|---------------|-------------------|
| | a mm | b mm | c mm | d mm | kg |
| 0.4 | 8 | 36 | 20 | 3 | 4.5 |
| 0.6 | 11 | 50 | 28 | 4 | 9.5 |
| 1 | 13 | 60 | 32 | 5 | 18 |
| 1.6 | 15 | 68 | 38 | 6 | 24 |
| 2 | 17 | 76 | 42 | 7 | 38 |
| 2.5 | 19 | 85 | 48 | 8 | 50 |
| 3 | 21 | 95 | 53 | 9 | 70 |
| 4 | 24 | 110 | 60 | 10 | 110 |
| 5 | 28 | 125 | 70 | 10.5 | 141 |
| 6 | 30 | 135 | 75 | 12 | 254 |
| 8 | 34 | 150 | 85 | 13 | 282 |
| 10 | 38 | 170 | 95 | 15 | 418 |
| 12 | 42 | 190 | 105 | 16 | 513 |
| 16 | 46 | 205 | 115 | 16 | 550 |
| 20 | 50 | 225 | 125 | 18 | 930 |
| 25 | 56 | 250 | 140 | 20 | 1303 |
| 31 | 62 | 280 | 155 | 21 | 1363 |
| 40 | 68 | 306 | 170 | 23 | 1930 |



E-6135
G-6135

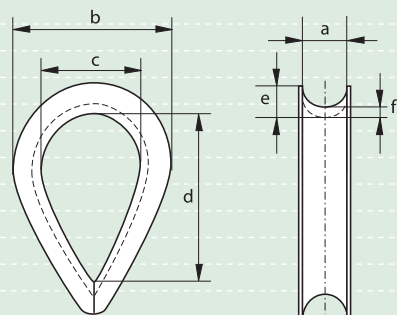

Guardacabos

Generalmente según DIN 3090

- **Material** : acero dulce
- **Norma** : generalmente según DIN 3090
- **Acabado** : en diámetros 4 y 6 mm. electro galvanizado otros diámetros galvanizado en caliente
- **Certificación** : bajo petición, certificado de fábrica

| diámetro cable | ancho ranura | ancho total | ancho interior | longitud interior | espesor | espesor chapa | peso cada 100 pcs |
|----------------|--------------|-------------|----------------|-------------------|---------|---------------|-------------------|
| mm | a mm | b mm | c mm | d mm | e mm | f mm | kg |
| 4 | 5 | 9 | 10 | 20 | 5.1 | 2.1 | 1.4 |
| 6 | 7 | 12 | 15 | 30 | 7.1 | 2.6 | 3 |
| 8 | 9 | 13 | 20 | 40 | 11 | 4 | 7.1 |
| 10 | 11 | 16 | 25 | 50 | 14 | 5 | 17 |
| 12 | 13 | 19 | 30 | 60 | 16 | 6 | 24 |
| 14 | 16 | 22 | 35 | 70 | 17 | 7 | 36 |
| 16 | 18 | 25 | 40 | 80 | 19 | 8 | 50 |
| 18 | 20 | 27 | 45 | 90 | 21 | 9 | 62 |
| 20 | 22 | 32 | 50 | 100 | 23 | 10 | 90 |
| 22 | 24 | 33 | 55 | 110 | 24 | 10 | 100 |
| 24 | 26 | 37 | 60 | 120 | 27 | 11 | 130 |
| 26 | 29 | 46 | 65 | 130 | 30 | 12 | 220 |
| 28 | 31 | 50 | 70 | 140 | 33 | 12 | 240 |
| 32 | 35 | 55 | 80 | 160 | 38 | 14 | 270 |
| 36 | 40 | 60 | 90 | 180 | 42 | 16 | 430 |
| 40 | 44 | 65 | 100 | 200 | 46 | 18 | 570 |
| 44 | 48 | 70 | 110 | 220 | 53 | 20 | 850 |
| 48 | 53 | 75 | 120 | 240 | 58 | 22 | 1120 |
| 52 | 57 | 80 | 130 | 260 | 64 | 25 | 1530 |
| 56 | 62 | 85 | 140 | 280 | 67 | 25 | 2148 |
| 60 | 66 | 90 | 150 | 300 | 70 | 25 | 2300 |
| 64 | 70 | 95 | 160 | 320 | 78 | 30 | 3500 |
| 68 | 75 | 100 | 170 | 340 | 81 | 30 | 3700 |
| 72 | 79 | 105 | 180 | 360 | 84 | 30 | 4100 |
| 76 | 84 | 115 | 190 | 380 | 87 | 30 | 4600 |
| 80 | 88 | 120 | 200 | 400 | 90 | 30 | 5400 |



S-6134

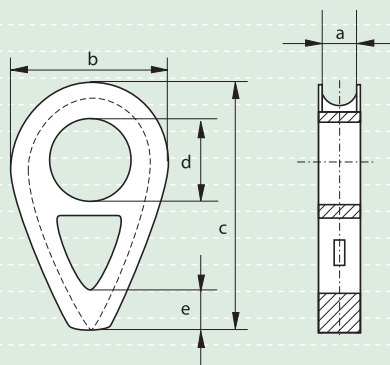

Guardacabos

Generalmente según DIN 3091

- **Material** : acero fundido (GTW 40)
- **Norma** : generalmente según DIN 3091
- **Acabado** : sin pintar
- **Certificación** : bajo petición, certificado de fábrica

| diámetro cable | ancho ranura | ancho total | longitud total | diámetro ojo | longitud de base | peso cada 100 pcs |
|----------------|--------------|-------------|----------------|--------------|------------------|-------------------|
| mm | a mm | b mm | c mm | d mm | e mm | kg |
| 8 | 9 | 40 | 66 | 14 | - | 18 |
| 10 | 11 | 50 | 82 | 18 | - | 32 |
| 12 | 13 | 60 | 98 | 21 | - | 52 |
| 14 | 16 | 70 | 114 | 25 | - | 80 |
| 16 | 18 | 80 | 130 | 28 | 16 | 90 |
| 18 | 20 | 90 | 145 | 31 | 18 | 121 |
| 20 | 22 | 100 | 161 | 35 | 20 | 161 |
| 22 | 24 | 110 | 177 | 38 | 22 | 211 |
| 24 | 26 | 120 | 193 | 41 | 24 | 271 |
| 26 | 29 | 130 | 209 | 44 | 26 | 355 |
| 28 | 31 | 140 | 224 | 47 | 28 | 420 |
| 32 | 35 | 160 | 256 | 53 | 32 | 630 |
| 36 | 40 | 180 | 288 | 59 | 36 | 884 |
| 40 | 44 | 200 | 320 | 65 | 40 | 1100 |
| 44 | 48 | 220 | 352 | 70 | 44 | 1500 |
| 48 | 53 | 240 | 384 | 76 | 48 | 2000 |
| 52 | 57 | 260 | 416 | 81 | 52 | 2500 |
| 56 | 62 | 280 | 448 | 86 | 56 | 3200 |
| 64 | 70 | 320 | 512 | 95 | 64 | 4600 |
| 72 | 79 | 360 | 576 | 104 | 72 | 6600 |
| 80 | 88 | 400 | 640 | 112 | 80 | 9000 |

1

2

3

4

5

6

7

8

9

10

11

12

13

14

15

16



G-6170

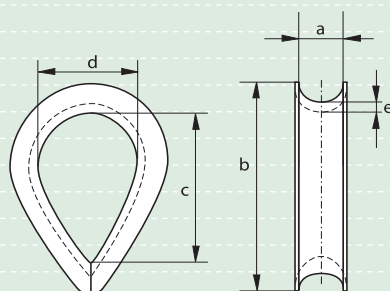

Guardacabos

Generalmente según BS 464

- **Material** : acero dulce
- **Norma** : generalmente según BS 464
- **Acabado** : galvanizado en caliente
- **Certificación** : bajo petición, certificado de fábrica

| diámetro cable | ancho ranura | longitud total | longitud interior | ancho interior | espesor chapa | peso cada 100 pcs |
|----------------|--------------|----------------|-------------------|----------------|---------------|-------------------|
| pulgadas | a mm | b mm | c mm | d mm | e mm | kg |
| 1/4 | 6 | 48 | 30 | 20 | 3.5 | 5.4 |
| 5/16 | 8 | 54 | 33 | 22 | 4 | 5.7 |
| 3/8 | 10 | 64 | 38 | 25 | 4.8 | 7.6 |
| 7/16 | 13 | 73 | 41 | 29 | 4.8 | 14.2 |
| 1/2 | 14 | 80 | 44 | 32 | 5.6 | 18 |
| 9/16 | 15 | 80 | 44 | 32 | 5.6 | 18.9 |
| 5/8 | 17 | 98 | 59 | 41 | 7.9 | 34 |
| 11/16 | 19 | 108 | 67 | 44 | 7.9 | 39.7 |
| 3/4 | 20 | 124 | 73 | 51 | 9.5 | 62.4 |
| 13/16 | 21 | 124 | 73 | 51 | 9.5 | 62.4 |
| 7/8 | 23 | 133 | 83 | 57 | 9.5 | 75.6 |
| 15/16 | 25 | 146 | 92 | 64 | 10.3 | 106 |
| 1 | 27 | 162 | 108 | 70 | 10.3 | 125 |
| 1 1/8 | 29 | 178 | 111 | 76 | 12.7 | 151 |
| 1 1/4 | 33 | 197 | 133 | 95 | 12.7 | 204 |
| 1 3/8 | 38 | 229 | 152 | 105 | 15.9 | 318 |
| 1 1/2 | 41 | 254 | 165 | 114 | 17.5 | 488 |
| 1 5/8 | 46 | 254 | 165 | 114 | 17.5 | 499 |
| 1 3/4 | 51 | 286 | 178 | 127 | 25.4 | 556 |
| 1 7/8 | 60 | 318 | 191 | 133 | 28.6 | - |
| 2 | 64 | 330 | 203 | 140 | 28.6 | - |
| 2 1/8 | 64 | 330 | 203 | 140 | 28.6 | - |
| 2 1/4 | 67 | 356 | 216 | 146 | 30.2 | - |
| 2 1/2 | 70 | 413 | 241 | 159 | 31.8 | - |
| 2 3/4 | 86 | 502 | 273 | 203 | 41.3 | - |

Guardacabos

Generalmente según US Fed.Spec. FF-T-276b Tipo III

- **Material** : acero dulce
- **Norma** : generalmente según US Fed.Spec. FF-T-276b Tipo III
- **Acabado** : galvanizado en caliente
- **Certificación** : bajo petición, certificado de fábrica



G-6142

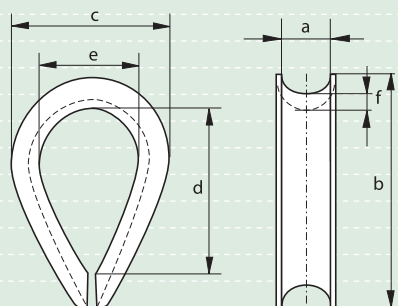

| diámetro cable | longitud total | ancho exterior | longitud interior | ancho interior | espesor chapa | peso cada 100 pcs |
|----------------|----------------|----------------|-------------------|----------------|---------------|-------------------|
| a pulgadas | b pulgadas | c pulgadas | d pulgadas | e pulgadas | f pulgadas | kg |
| 1/4 | 2 3/16 | 1 1/2 | 1 5/8 | 7/8 | 1/16 | 3.4 |
| 5/16 | 2 1/2 | 1 13/16 | 1 7/8 | 1 1/16 | 5/64 | 6.3 |
| 7/16 | 3 1/4 | 2 3/8 | 2 3/8 | 1 1/4 | 1/8 | 16.2 |
| 1/2 | 3 5/8 | 2 3/4 | 2 3/4 | 1 1/2 | 9/64 | 23 |
| 9/16 | 3 5/8 | 2 11/16 | 2 3/4 | 1 1/2 | 9/64 | 23 |
| 5/8 | 4 1/4 | 3 1/8 | 3 1/4 | 1 3/4 | 5/32 | 33.8 |
| 3/4 | 5 | 3 13/16 | 3 3/4 | 2 | 7/32 | 66.2 |
| 7/8 | 5 1/2 | 4 1/4 | 4 1/4 | 2 1/4 | 7/32 | 83.3 |
| 1 | 6 1/8 | 4 15/16 | 4 1/2 | 2 1/2 | 1/4 | 135 |
| 1 1/8 - 1 1/4 | 7 | 5 7/8 | 5 1/8 | 2 7/8 | 1/4 | 185 |
| 1 1/4 - 1 3/8 | 8 1/16 | 6 13/16 | 6 1/4 | 3 1/2 | 1/2 | 375 |
| 1 3/8 - 1 1/2 | 9 | 7 1/8 | 6 1/2 | 3 1/2 | 1/2 | 540 |
| 1 5/8 | 11 1/4 | 8 1/8 | 8 | 4 | 1/2 | 731 |
| 1 3/4 | 12 3/16 | 8 1/2 | 9 | 4 1/2 | 1/2 | 810 |
| 1 7/8 - 2 | 15 1/8 | 10 3/8 | 12 | 6 | 1/2 | 1170 |
| 2 1/4 | 17 1/8 | 11 7/8 | 14 | 7 | 1/2 | 1935 |
| 2 1/2 | 18 1/4 | 12 1/4 | 14 7/8 | 7 | 3/4 | - |
| 3 | 20 1/4 | 14 | 16 1/2 | 7 7/8 | 3/4 | - |

Guardacabos

Guardacabos tipo remolque

- **Material** : acero dulce
- **Acabado** : galvanizado en caliente
- **Certificación** : bajo petición, certificado de fábrica
- **Opciones** : material más grueso
reforzado
placa soldada
topes



G-6160

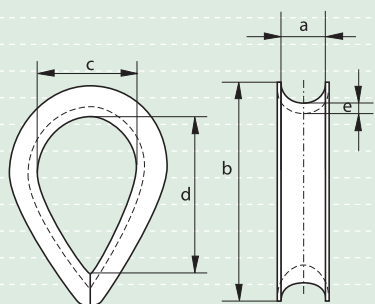

| circunferencia cabo | ancho ranura | longitud total | ancho interior | longitud interior | espesor chapa | peso unid. |
|------------------------|-----------------|-------------------|-------------------|----------------------|------------------|---------------|
| pulgadas | a mm | b mm | c mm | d mm | e mm | kg |
| 5 | 44 | 200 | 90 | 140 | 6 | 2 |
| 6 | 54 | 230 | 100 | 160 | 8 | 3 |
| 7 | 62 | 270 | 120 | 190 | 8 | 4 |
| 8 | 70 | 290 | 130 | 200 | 8 | 5 |
| 9 | 80 | 360 | 150 | 235 | 10 | 9.5 |
| 10 | 90 | 400 | 160 | 245 | 10 | 11.5 |
| 12 | 100 | 430 | 170 | 260 | 10 | 13.5 |
| 13 | 120 | 480 | 170 | 280 | 13 | 22 |
| 14 | 130 | 490 | 180 | 300 | 13 | 24 |
| 15 | 150 | 520 | 190 | 310 | 15 | 29 |
| 16 | 160 | 550 | 200 | 320 | 15 | 37 |



G-6151

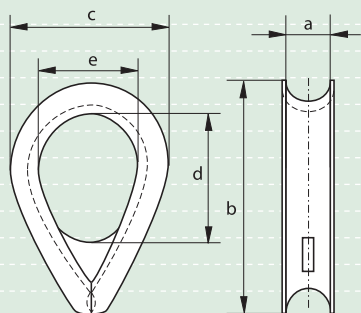

Guardacabos

Guardacabos para "pennant lines"

- **Material** : acero dulce
- **Acabado** : galvanizado en caliente,
fabricados con placa soldada
- **Certificación** : bajo petición, certificado de fábrica

| diámetro cable | ancho ranura | longitud total | ancho exterior | longitud interior | ancho interior | peso unid. |
|-------------------|-----------------|-------------------|-------------------|----------------------|-------------------|---------------|
| mm | a mm | b mm | c mm | d mm | e mm | kg |
| 16 | 17 | 102 | 75 | 75 | 50 | 0.4 |
| 18 | 19 | 115 | 85 | 80 | 53 | 0.5 |
| 20 | 21 | 127 | 100 | 90 | 60 | 0.8 |
| 22 | 23 | 140 | 110 | 95 | 65 | 0.9 |
| 24 | 25 | 153 | 115 | 120 | 70 | 1 |
| 30 | 33 | 205 | 155 | 160 | 100 | 2.5 |
| 36 | 38 | 230 | 175 | 185 | 115 | 4 |
| 40 | 41 | 255 | 190 | 195 | 120 | 4.5 |
| 44 | 46 | 280 | 210 | 215 | 130 | 7 |
| 50 | 52 | 305 | 225 | 240 | 140 | 8.3 |
| 56 | 56 | 360 | 240 | 250 | 150 | 12.5 |
| 64 | 70 | 435 | 290 | 310 | 180 | 19.5 |
| 76 | 81 | 485 | 320 | 360 | 220 | 29 |
| 82 | 92 | 560 | 375 | 405 | 240 | 35 |
| 90 | 105 | 610 | 410 | 450 | 250 | 42 |
| 120 | 130 | 660 | 450 | 480 | 280 | 58 |



E-6180

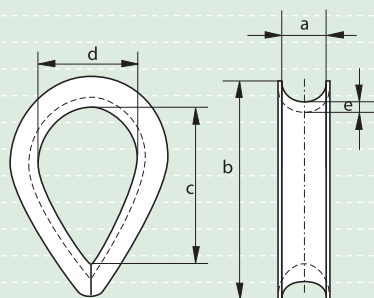

Guardacabos

Guardacabos para cabos

- **Material** : acero dulce
- **Acabado** : electro galvanizado
- **Certificación** : bajo petición, certificado de fábrica

| ancho ranura | longitud total | longitud interior | ancho interior | espesor chapa | peso cada 100 pcs |
|--------------|----------------|-------------------|----------------|---------------|-------------------|
| a mm | b mm | c mm | d mm | e mm | kg |
| 8 | 43 | 27 | 16 | 1 | 1.1 |
| 10 | 50 | 30 | 19 | 1.5 | 1.7 |
| 12 | 55 | 36 | 22 | 1.75 | 3 |
| 14 | 60 | 41 | 24 | 2 | 3.5 |
| 16 | 66 | 43 | 26 | 2.5 | 8 |
| 18 | 77 | 47 | 30 | 3 | 13 |
| 20 | 91 | 58 | 35 | 3 | 16 |
| 22 | 100 | 67 | 38 | 3 | 24 |
| 25 | 115 | 71 | 45 | 3 | 25 |
| 30 | 140 | 91 | 55 | 3 | 43 |
| 35 | 140 | 91 | 55 | 3 | 45 |
| 38 | 140 | 91 | 55 | 4 | 45 |

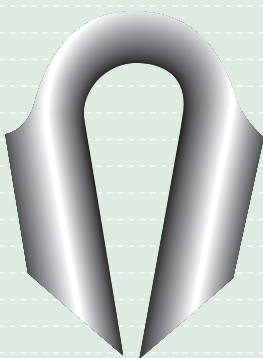

P-6190

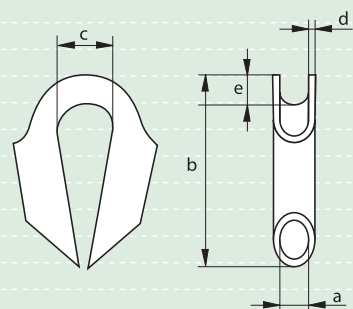

Guardacabos

Guardacabos tubulares

- **Material** : acero dulce
- **Acabado** : pintado azul
- **Certificación** : bajo petición, certificado de fábrica

| diámetro cable | diámetro tubo | longitud total | ancho interior | espesor chapa | profundidad ranura | peso cada unid. |
|----------------|---------------|----------------|----------------|---------------|--------------------|-----------------|
| mm | a mm | b mm | c mm | d mm | e mm | kg |
| 10 | 12 | 90 | 23 | 4 | 8 | 0.25 |
| 12 | 15 | 105 | 27 | 5 | 10 | 0.42 |
| 14 | 17 | 115 | 27 | 5 | 10 | 0.5 |
| 16 | 19 | 120 | 32 | 5 | 12 | 0.6 |
| 18 | 22 | 140 | 35 | 5 | 15 | 0.75 |
| 22 | 25 | 180 | 45 | 6 | 16 | 1.4 |
| 24 | 28 | 180 | 45 | 7 | 16 | 1.75 |
| 26 | 30 | 195 | 47 | 7 | 18 | 2 |
| 32 | 35 | 215 | 60 | 7 | 22 | 2.4 |
| 38 | 45 | 260 | 70 | 7 | 27 | 3.3 |
| 44 | 50 | 280 | 75 | 7 | 28 | 4.06 |

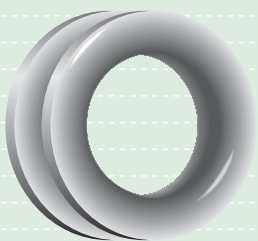

E-6143
G-6143

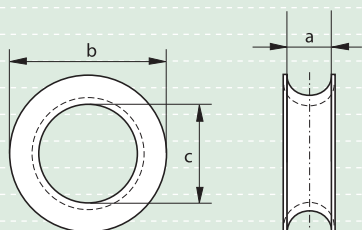

Guardacabos redondos

Tipo normal

- **Material** : acero dulce
- **Acabado** : hasta 13 mm. electro galvanizado
superior a 13 mm. galvanizado en caliente
- **Certificación** : bajo petición, certificado de fábrica

| ancho ranura | diámetro exterior | diámetro interior | peso cada 100 pcs |
|--------------|-------------------|-------------------|-------------------|
| a mm | b mm | c mm | kg |
| 10 | 30 | 18 | 1.4 |
| 12 | 33 | 20 | 2.6 |
| 13 | 39 | 24 | 3.4 |
| 14 | 41 | 28 | 4 |
| 15 | 45 | 30 | 5 |
| 16 | 50 | 35 | 6.5 |
| 18 | 56 | 40 | 8 |
| 20 | 60 | 42 | 9 |
| 22 | 65 | 45 | 10.5 |
| 25 | 80 | 52 | 25 |
| 28 | 98 | 60 | 43 |
| 30 | 105 | 65 | 65 |
| 35 | 120 | 75 | 90 |
| 40 | 135 | 80 | 95 |

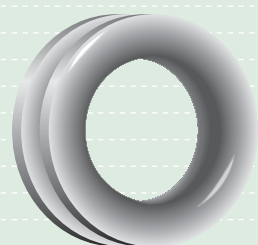

G-6144

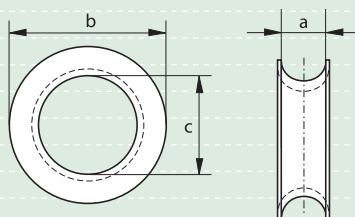

Guardacabos redondos

Tipo container

- **Material** : acero dulce
- **Acabado** : galvanizado en caliente
- **Certificación** : bajo petición, certificado de fábrica

| ancho ranura | diámetro exterior | diámetro interior | peso cada 100 pcs |
|--------------|-------------------|-------------------|-------------------|
| a mm | b mm | c mm | kg |
| 14 | 80 | 45 | 35 |
| 14 | 92 | 55 | 41 |
| 14 | 96 | 60 | 44 |
| 16 | 80 | 45 | 35 |
| 16 | 92 | 55 | 41 |
| 16 | 96 | 60 | 44 |
| 19 | 80 | 45 | 35 |
| 19 | 92 | 55 | 41 |
| 19 | 96 | 60 | 44 |

1

2

3

4

5

6

7

8

9

10

11

12

13

14

15

16